

Uniclass L721:N14:N5352	EPIC H12:Y311	
CI/SfB	(74.29)	X (U35)

CTSC/05/2004

CHANGING TABLE & SHOWER CHANGER

Assisted showering and changing

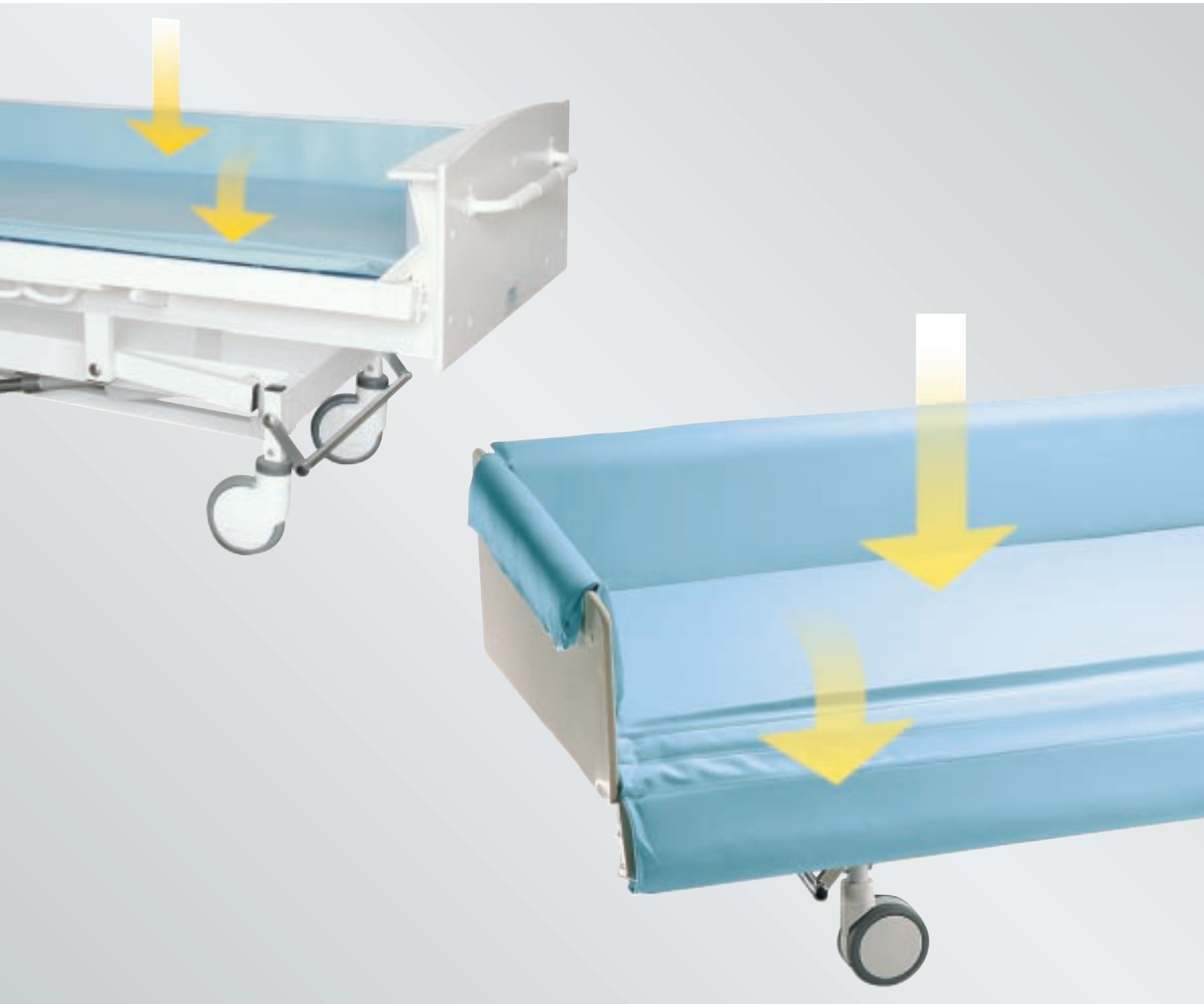

CHANGING TABLE

Assisted changing

The Changing Table is available in a standard size of 2000mm and can also be custom manufactured for specific client needs. The load bearing dropside design allows easy access and the raise/lower feature enables safe transfer at a low level and reduces back strain for the Carer when raised. Transfer can take place without a hoist, although the Changing Table can be used with fixed, mobile and ceiling-mounted hoist systems.

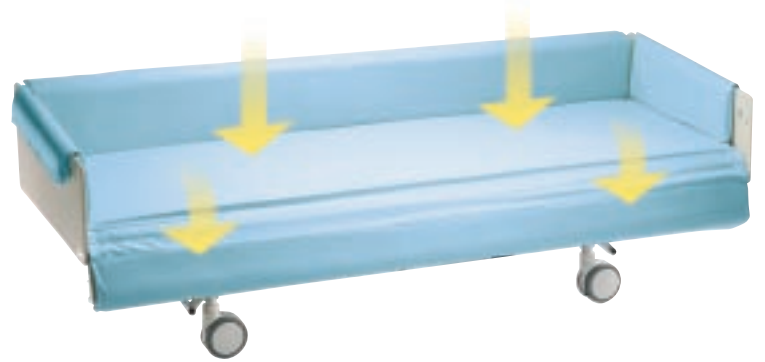

standard features

- Battery powered raise & lower
- Fully cushioned
- Single opening side
- Lockable castors

additional options

- Twin opening side
- Static model
- Custom size manufacture
- Range of removable supports

SHOWER CHANGER

Assisted showering and changing

The Shower Changer is available in 2 standard sizes and can also be custom manufactured for specific client needs. The Shower Changer opens on both sides to form a large changing area. The raise/lower feature enables safe transfer at a low level and reduces back strain for the carer when raised.



standard features

- Battery powered raise & lower
- Fully cushioned to base and fold side
- Twin opening side
- Drain hose with storage clip
- Grab handles to each end
- Lockable castors

additional options

- Static model
- Custom size manufacture
- Range of removable supports
- Wall mounted mixer valve assembly

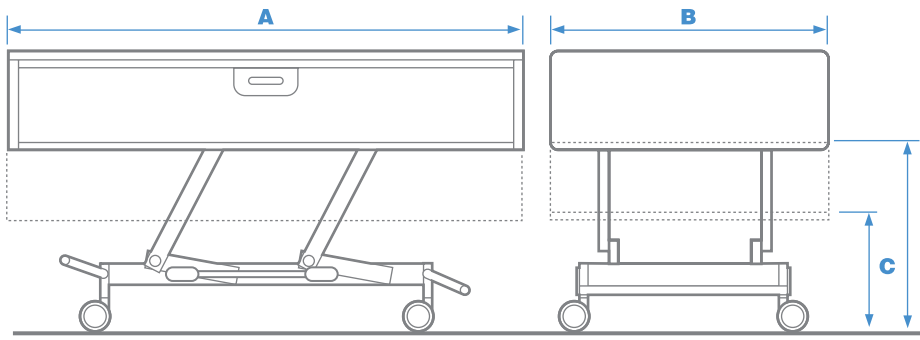

CHANGING TABLE (Standard model dimensions)

A	B	C
Req'd. space to allow free travel up/down*	Width	Base height approx.
2100	800	Min.460 Max.860

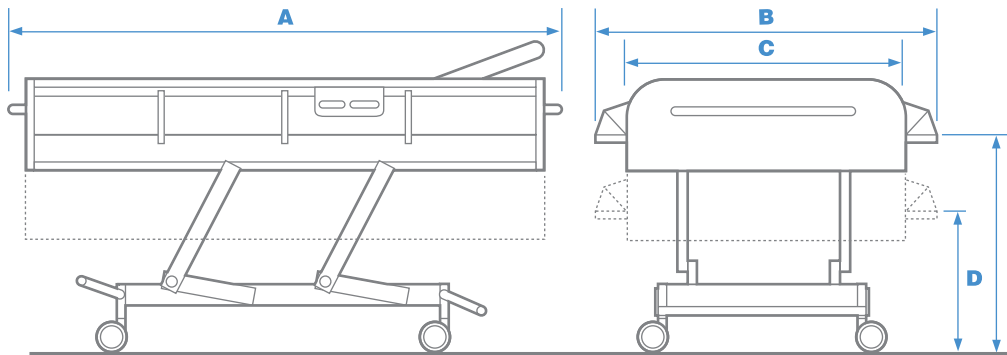

SHOWER CHANGER

Size	A	B	C	D	Internal width sides up	Internal length
	Req'd. space to allow free travel up/down*	Exterior width sides down	Exterior width sides up	Base height approx.		
Medium	2090	880	780	Min. 460	580	1680
Large	2350	940	840	Max. 860	640	1950

All dimension expressed in millimetres

*Standard frame travel clearance required – for confined areas a vertical rise frame is available

Maximum Load : 130kg/21st

Kingkraft Customer Care

The following services are offered to make the process of choosing your Kingkraft product as straight forward as possible. Kingkraft Care continues following delivery to ensure the products continue to provide the maximum benefit.

- Product demonstration and assessments
- Bathroom layout design and drawing
- Technical support both prior to order and following delivery
- Product commissioning
- 12 month product warranty (extended warranties available)
- On-going product servicing and preventative maintenance schemes

For full details of these services please contact our customer service department or refer to our product information folder.



Kingkraft Limited, 26D Orgreave Crescent, Dore House Industrial Estate, Sheffield S13 9NQ
 Telephone: 0114 269 0697 Fax: 0114 269 5145 Email: info@kingkraft.co.uk Web: www.kingkraft.co.uk

Due to the process of continuous development we reserve the right to alter specification without notice.